



Workshop
Institute of Aviation (IoA)
Warsaw, July 7- 8, 2009



Coupled - Engine Power Unit

Institute of Aviation, Poland
Warsaw University of Technology, Poland



The idea

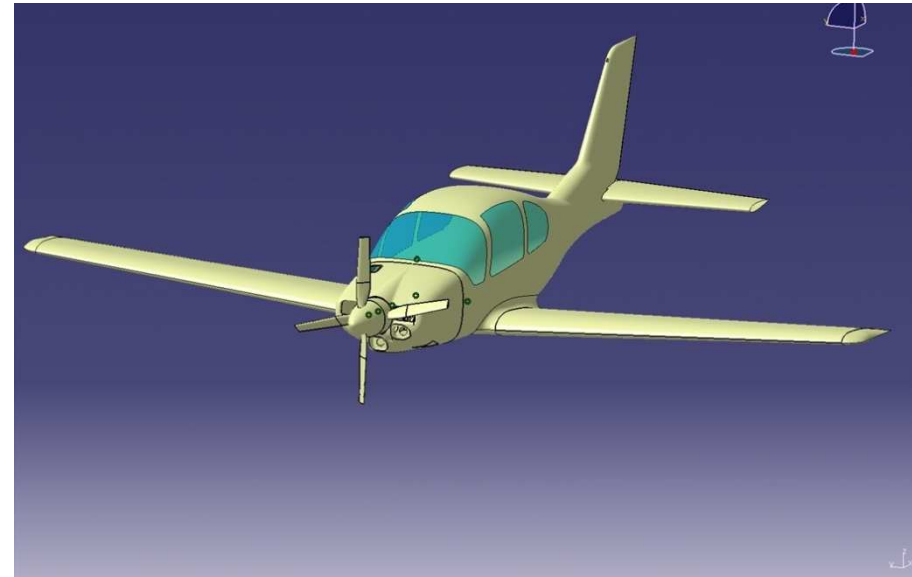
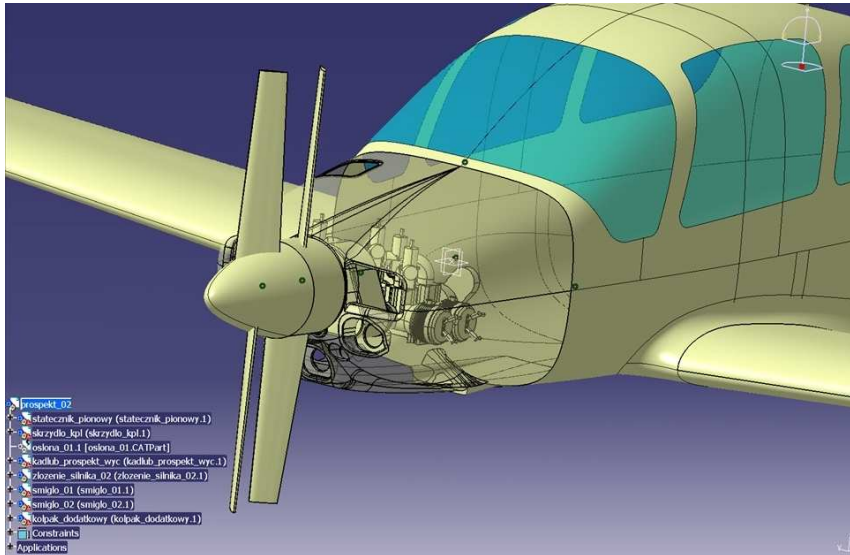

The Coupled Engine Power Unit (CEPU) idea could be proposition for the next generation power pack for future small-size GA aircraft.

It is an alternative advanced propulsion.



Workshop

IoA Warsaw, July 7- 8 , 2009

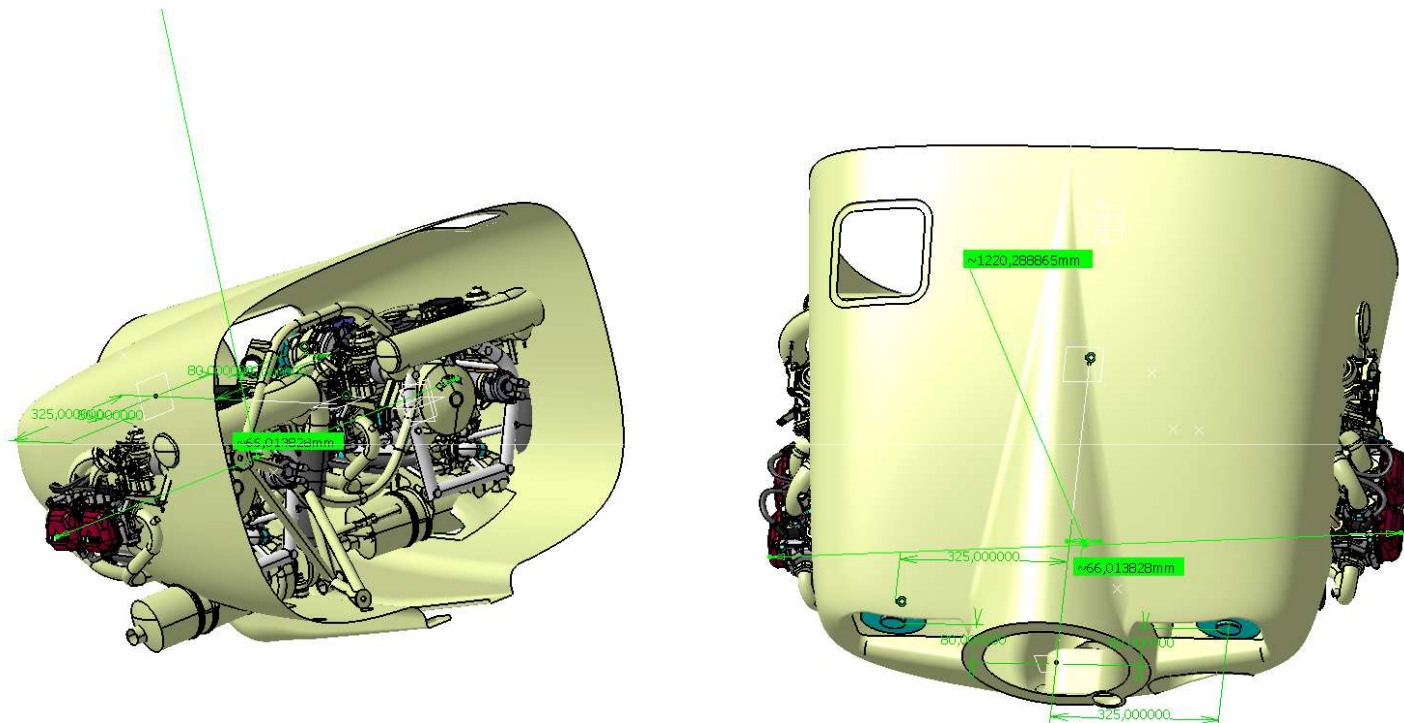

Preliminary analysis of CEPU power system configuration on the I-23 plane – Two Rotax 914F engines (2 x 115 HP), compared to the shield of actual single engine (Lycoming 360)



The CEPU idea allows to:

- build twin engine aircraft with single engine mount,
- security (unit of two engines),
- gyroscope and torque moments are zeroed,
- vibration level is reduced,
- aerodynamic drag of aircraft is reduced.



Workshop IoA Warsaw, July 7- 8 , 2009



Source of Idea ...



Engine Powered Parachute Wing PARAFAN

The patented power unit consisted of the KFM piston engine and two counter-rotating over-ducted propellers. Two counter-rotating propellers eliminate reaction and gyroscopes moments easing control of the machine.



Workshop

IoA Warsaw, July 7- 8 , 2009

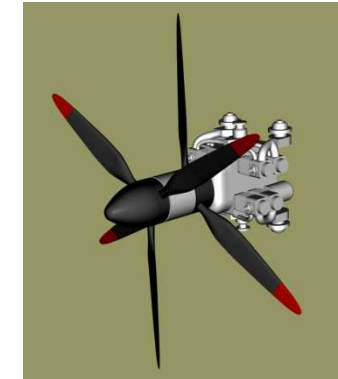
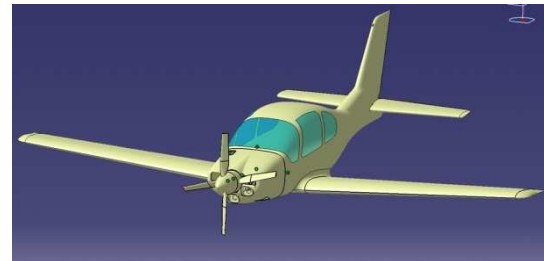
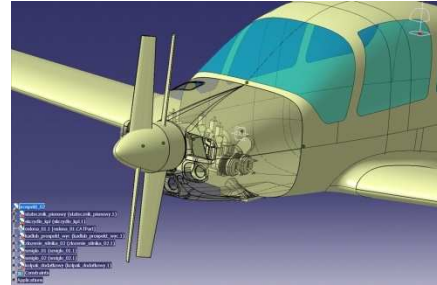

Classic: single or two engines

Coupled - Engine Power Unit

Compact Piston or Electric Engine

Today

For 3 - 6 years

Future



Workshop
IoA Warsaw, July 7- 8 , 2009



Future applications of CEPU idea

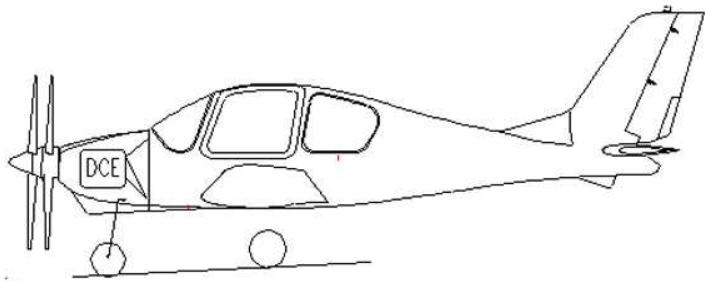
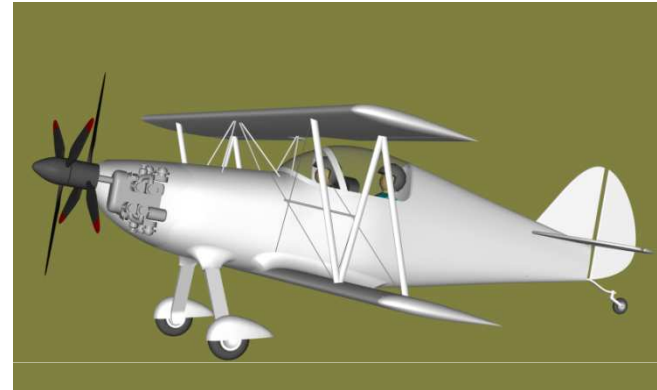



Patent application

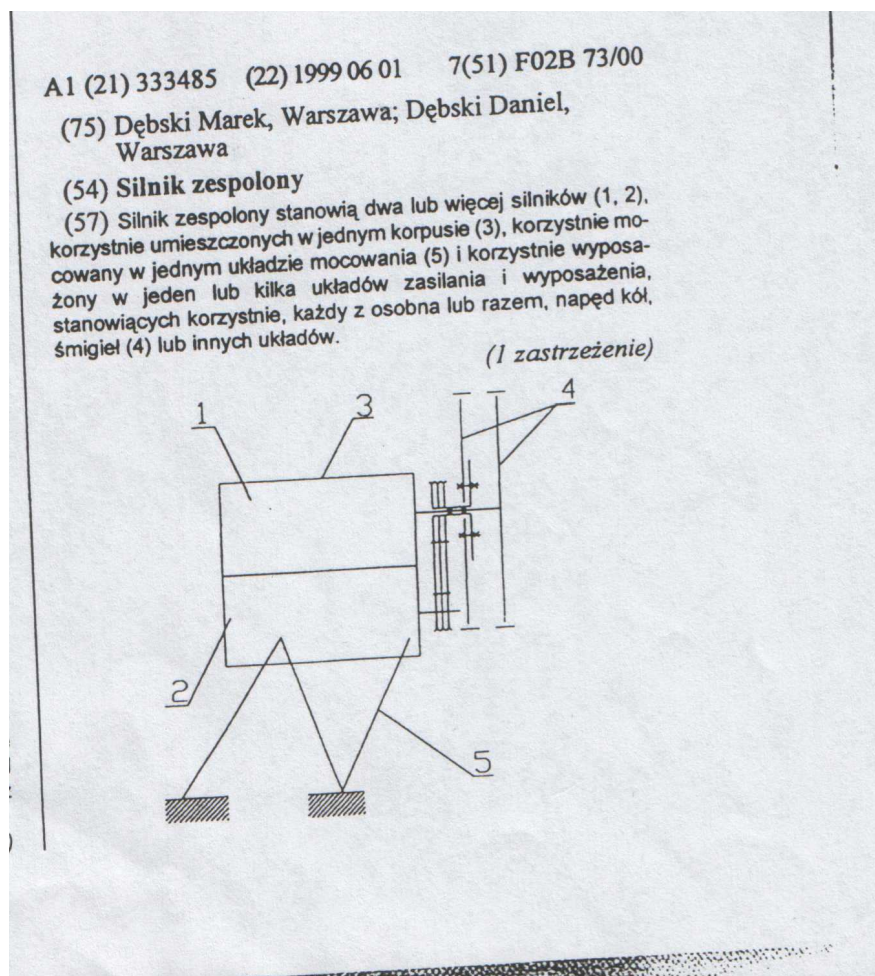



Workshop

IoA Warsaw, July 7- 8 , 2009



Objectives:

- Coupled Piston Engines Unit for very small-size GA aircraft

Description of work/Technical approach:

- Design and economic analysis CPEU idea for very small-size GA aircraft

Deliverables:

- Evaluation of the CPEU idea for very small-size GA aircraft



Workshop

IoA Warsaw, July 7- 8 , 2009



Expected results:

- high safety,
- the level of vibration is reduced,
- two engines built-in in aircraft with the single engine mount,
- gyroscope and torque moments are zeroed,
- the aerodynamic drag is reduced'



Workshop
Institute of Aviation (IoA)
Warsaw, July 7- 8, 2009



THANK YOU FOR YOUR ATTENTION

Marek Dębski
Contact: dedal@ilot.edu.pl